

- Item: Dielectric Patch Antenna Element for GPS L1 Band
- Part Number: ANPS1580H4ZTA



### ■ Electric Specification

ITEM	SPECIFICATION	UNIT	CONDITIONS
Outline Dimension	12x12x4	mm	
Center frequency	1575.42	MHz	@30x30mm Ground Plane
Bandwidth	3.0	MHz typ.	@ -10dB Return Loss
Gain at Zenith	- 1.0	dBic typ.	@30x30mm Ground Plane
Axial Ratio	3.0	dB typ.	@ Center frequency
Impedance	50	$\Omega$	
Polarization	RHCP		
TemperatureCoefficient	20	ppm/°C	-40°C to +85°C

### ■ Dimension

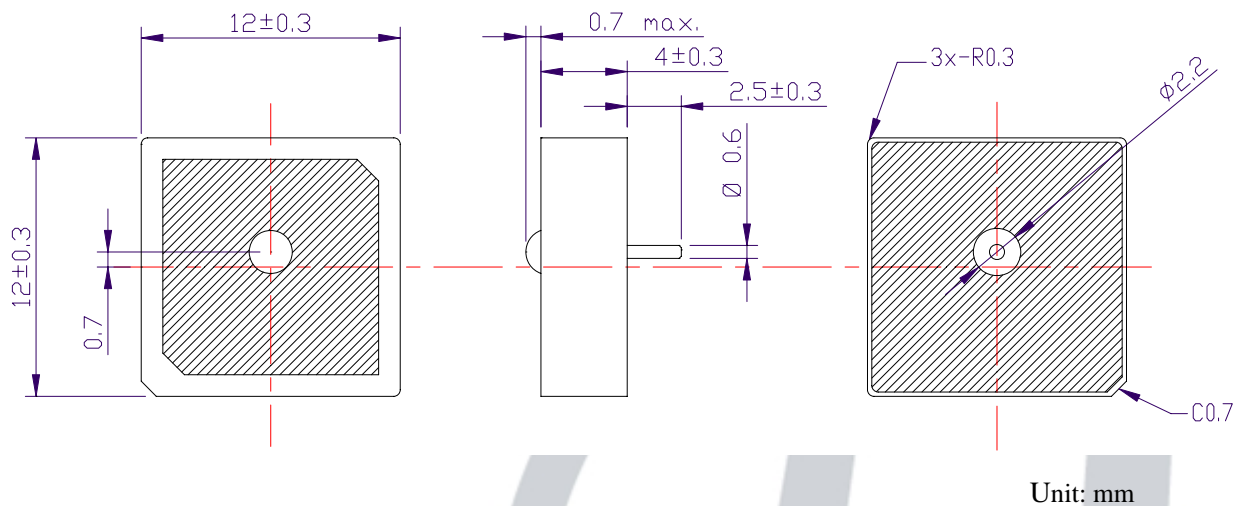

## ■ Typical Characteristics

### -Smith Chart & Return Loss

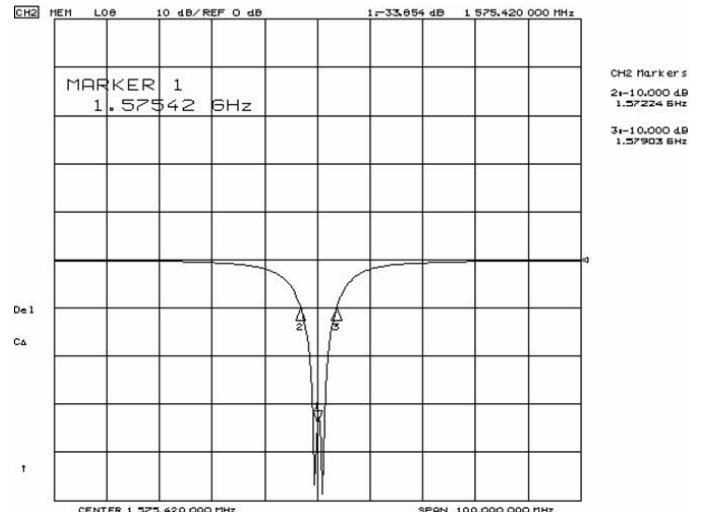
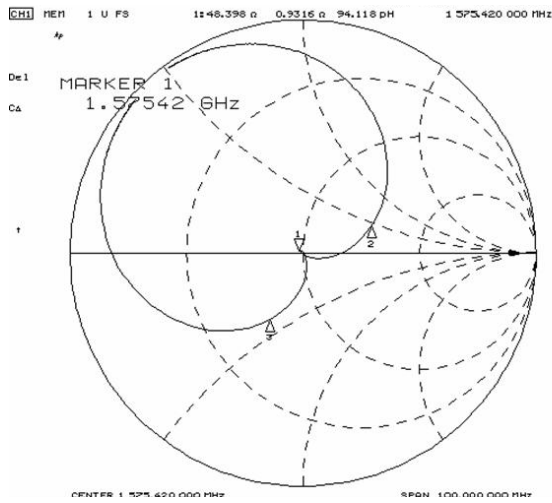

### -Radiation Pattern

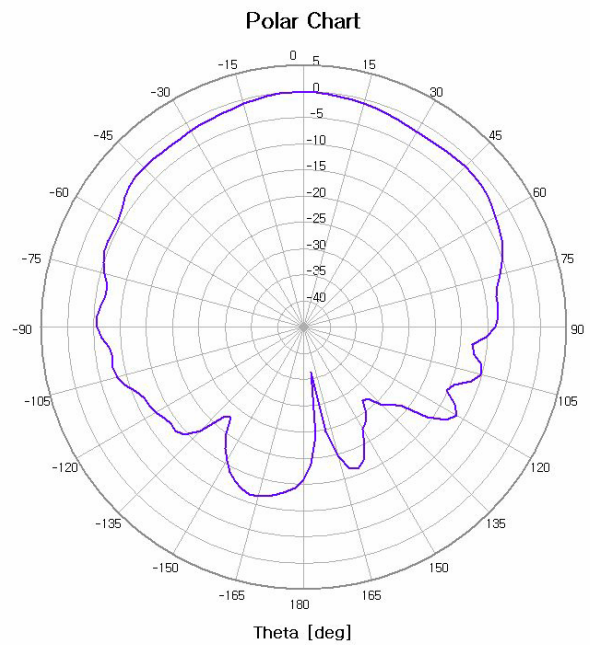
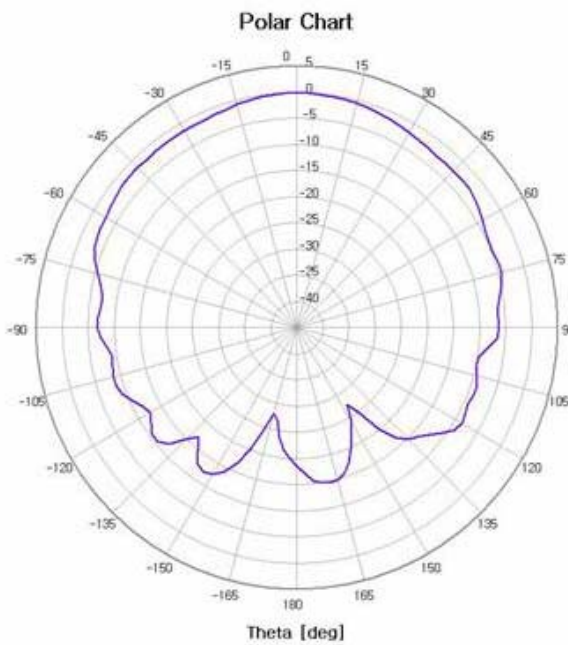
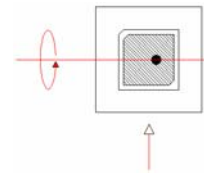
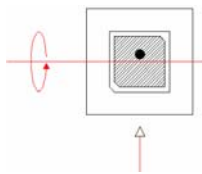

■ Measurement condition

S-parameter and Return Loss(VSWR) measurement

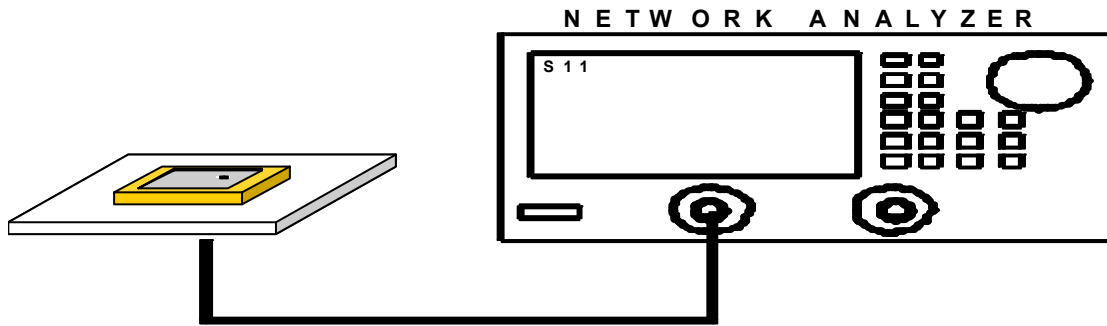

Gain measurement

